



24 Cam Latch

Flush T-handle · Adjustable grip

- Concealed mounting type

Material and Finish

Zinc and steel, zinc plated or stainless steel

Performance Details

Max. static load: 445 N (100 lbf)

Installation Notes

Max. tightening torque of mounting nuts not to exceed 2.8 N·m (25 in·lbf)

Keys

See page 98

Other options available. For complete details on variety, part numbers, installation and specification, go to



www.southco.com/24

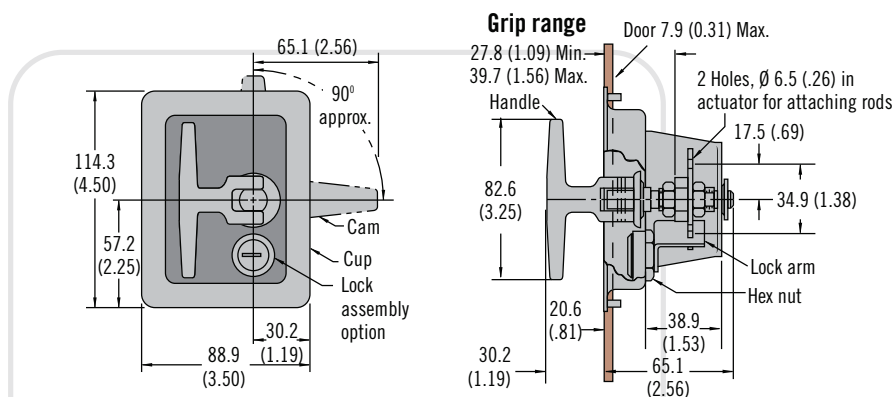

Part Number		
Style	With Mounting Studs	
	Cup and bracket polished stainless steel. Handle zinc chrome plated	Cup and bracket steel dactrotized. Handle zinc dactrotized
	Type A	Type A
Locking keyed alike CH751 supplied	24-20-812-35	24-20-812-10
Non-locking	24-20-302-35	24-20-302-10
Non-locking environmentally sealed	24-20-312-35	24-20-312-10



69 Cam Latch

Arrowhead · Detent design · Adjustable grip

- Single hole install
- Detented design
- Adjustable grip

Material and Finish

Nylon and steel, zinc plated

Performance Details

Small working load: 44 N (10 lbf)

Medium working load: 220 N (50 lbf)

Large working load 330 N: (75 lbf)

Other options available. For complete details on variety, part numbers, installation and specification, go to



www.southco.com/69

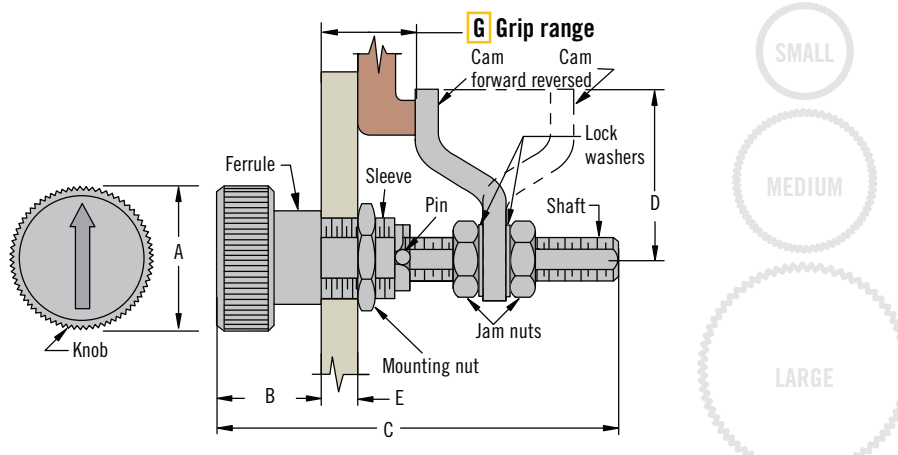

Size	Part Number	Grip range		A	B	C	D	E
		Min.	Max.					
Small	69-10-301-11	4 (.16)	28.2 (1.11)	12.7 (.50)	12.7 (.50) Max.	38.1 (1.50)	13.5 (.53)	4.75 (.188)
Medium	69-10-401-11	3.2 (.13)	33.3 (1.31)	19.1 (.75)	17.5 (.69) Max.	47.5 (1.87)	15.9 (.63)	6.35 (.25)
Large	69-10-501-11	4.8 (.19)	61.9 (2.44)	28.6 (1.13)	25.4 (1) Max.	79.2 (3.12)	34.1 (1.34)	12.7 (.50)

Dimensions in millimeters (inch) unless otherwise stated