

REV.	MODIFICATION.	DATE	DRN
01	NEW DRAWING	18/10/04	NJB
02	ECN2006-063	20/03/06	OW
03	ECN06-227	03/10/06	NJB

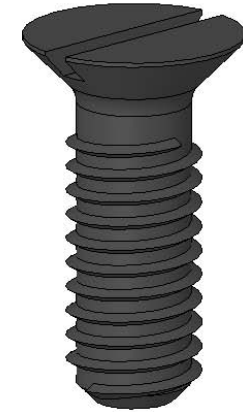
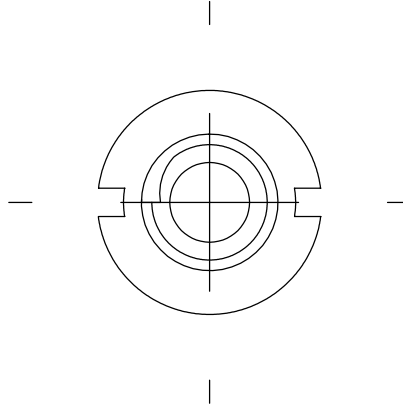
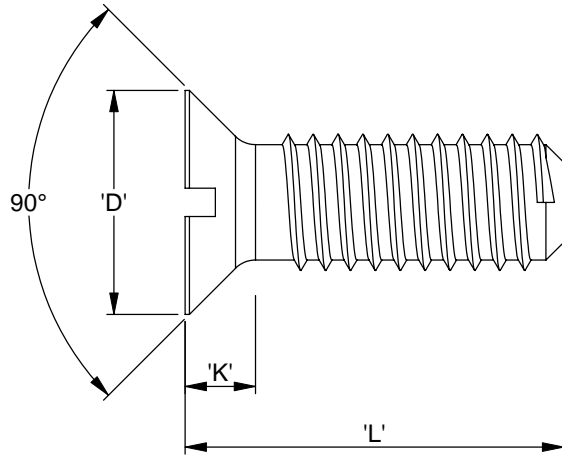

NOTES:  
 1a) Metric primary units:mm.  
 b) Imperial secondary units: [Inches].

NSE-2009-M6-L	8.0 10.0 12.0 16.0 20.0 25.0 30.0 40.0 50.0 60.0 [.315] [.394] [.473] [.630] [.788] [.985] [1.182] [1.575] [1.969] [2.363]	11.3 [.444]	3.3 [.129]
NSE-2009-M5-L	7.0 8.0 10.0 12.0 15.0 16.0 18.0 20.0 25.0 30.0 35.0 40.0 [.276] [.315] [.394] [.473] [.591] [.630] [.709] [.788] [.985] [1.182] [1.377] [1.575]	9.3 [.366]	2.7 [.106]
NSE-2009-M4-L	6.0 8.0 10.0 12.0 15.0 16.0 20.0 25.0 30.0 35.0 [.236] [.315] [.394] [.473] [.591] [.630] [.788] [.985] [1.182] [1.377]	8.4 [.330]	2.7 [.106]
NSE-2009-M3-L	5.0 6.0 8.0 16.0 20.0 25.0 30.0 42.0 [.197] [.236] [.315] [.630] [.788] [.985] [1.182] [1.654]	5.5 [.216]	1.65 [.064]
PART REF:	L	D	K

<p>INFORMATION CONTAINED IN THIS DOCUMENT IS CONFIDENTIAL TO RICHCO INTERNATIONAL Co. Ltd. AND MAY NOT BE DISCLOSED OR REPRODUCED IN WHOLE OR PART WITHOUT THEIR WRITTEN CONSENT</p>					
			<p>GENERAL TOLERANCES ±0.25 [0.010]          ARE FOR REFERENCE UNLESS OTHERWISE          1 DECIMAL PLACE ±          2 DECIMAL PLACES ±          ANGULAR ±1°</p>		
<p>MATERIAL:  <b>NYLON 6/6 (RMS-179)</b></p>			<p>COLOUR:  <b>NATURAL</b></p>		
<p>TITLE:  <b>METRIC SCREW          (DIN EN ISO 2009)</b></p>			<p>PART No:  <b>NSE-2009-MX-L</b></p>		
<p>DRG No:  <b>04-116</b></p>		<p>NPR REF:</p>		<p>SIZE  <b>A4</b></p>	
<p>DRN  <b>NJB</b></p>	<p>DATE  <b>18/10/04</b></p>	<p>CHKD  <b>I.C</b></p>	<p>DATE  <b>18/10/04</b></p>	<p>SCALE  <b>NTS</b></p>	<p>SHEET No  <b>1 OF 1</b></p>