

A B C D E F

REV.	MODIFICATION.	DATE	DRN
A	NEW DRAWING	23/03/95	RMB
B	SCN95-030	21/07/95	PTG
C	SCN96-022	12/04/96	RMB
D	SCN03-031	06/02/03	NJB
05	ECR05-064	18/05/05	OW
06	ECR05-085	09/08/05	OW
07	ECN07-029	08/02/07	SF
08	ECN07-109	02/07/07	SF
09	CO2010267	07/07/08	SF
10	CO2010945	22/06/10	SF

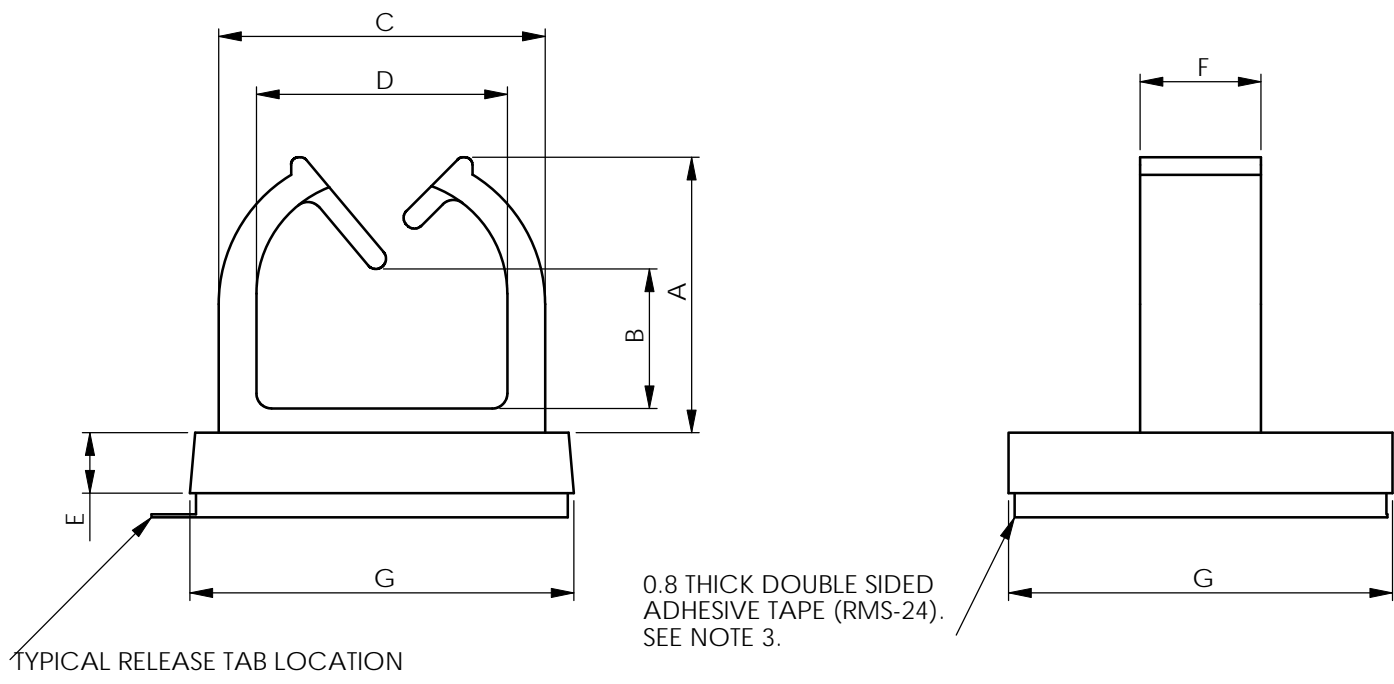

- NOTES**
- 1a) METRIC PRIMARY UNITS:mm
 - 1b) IMPERIAL SECONDARY UNITS: [inches]
 - 2) MIS-MATCH TOLERANCE ± 0.04 FOR BASE ASSEMBLY REQUIREMENTS
 - 3) PARTS AVAILABLE IN HIGH BOND CONVERTEX 2110 TAPE BY SPECIAL ORDER, ADD 2110 TO THE END OF THE PART DESCRIPTION, E.G MWSEB-3-01A-RT 2110.
 - 4) MWSEB-5-19A-RT CUSTOMER REF: TMM8E18052.
 - 5) PARTS ARE NATURAL AS STANDARD BUT ARE ALSO AVAILABLE IN BLACK. ADD BK TO END OF THE PART DESCRIPTION, E.G. MWSEB-5-01A-RT-BK.
 - 6) THE COLOUR OF THE ADHESIVE LINER MAY VARY. THIS THIS WILL NOT AFFECT THE TECHNICAL PROPERTIES OF THE PART.

PART NUMBER		"A" REF	"B" REF	"C"	"D"	"E"	"F"	"G"
NYLON 6/6(RMS-01)	NYLON 6/6 FR(RMS-19)							
MWSEB-1-01A2-RT	MWSEB-1-19A2-RT	4.1[.16]	1.0[.04]	7.1[.28]	4.6[.18]	1.5[.06]	2.0[.08]	9.5[.37]
MWSEB-2-01A2-RT	MWSEB-2-19A2-RT	6.1[.24]	2.8[.11]					
MWSEB-3-01A2-RT	MWSEB-3-19A2-RT	7.4[.29]	3.0[.12]	9.1[.36]	6.4[.25]	2.0[.08]	4.1[.16]	12.7[.50]
MWSEB-4-01A2-RT	MWSEB-4-19A2-RT	9.1[.36]	4.1[.16]	10.7[.42]	7.9[.31]			
MWSEB-5-01A2-RT	MWSEB-5-19A2-RT	11.2[.44]	6.1[.24]	11.9[.47]	8.9[.35]			
MWSEB-6-01A2-RT	MWSEB-6-19A2-RT	13[.51]	7.6[.30]					

ALTERNATE UNITS FOR REFERENCE ONLY

INFORMATION CONTAINED IN THIS DOCUMENT IS CONFIDENTIAL TO RICHCO INTERNATIONAL Co. Ltd. AND MAY NOT BE DISCLOSED OR REPRODUCED IN WHOLE OR PART WITHOUT THEIR WRITTEN CONSENT.

RICHCO, INC.
WWW.RICHCO-INC.COM

GENERAL TOLERANCES ±0.25 [0.010] UNLESS OTHERWISE STATED
1 DECIMAL PLACE ±
2 DECIMAL PLACES ±
ANGULAR ±1°

THIRD ANGLE

MATERIAL: SEE TABLE COLOUR: SEE NOTE 5

DESCRIPTION: SEE TABLE PART No: SEE TABLE

DRG No: 05-055 NPR No: N/A SHEET SIZE A4

DRN OW DATE 18/05/05 CHKD NBr DATE 18/05/05 SCALE NTS SHEET No. 1 OF 1