

GN 2422

Rails

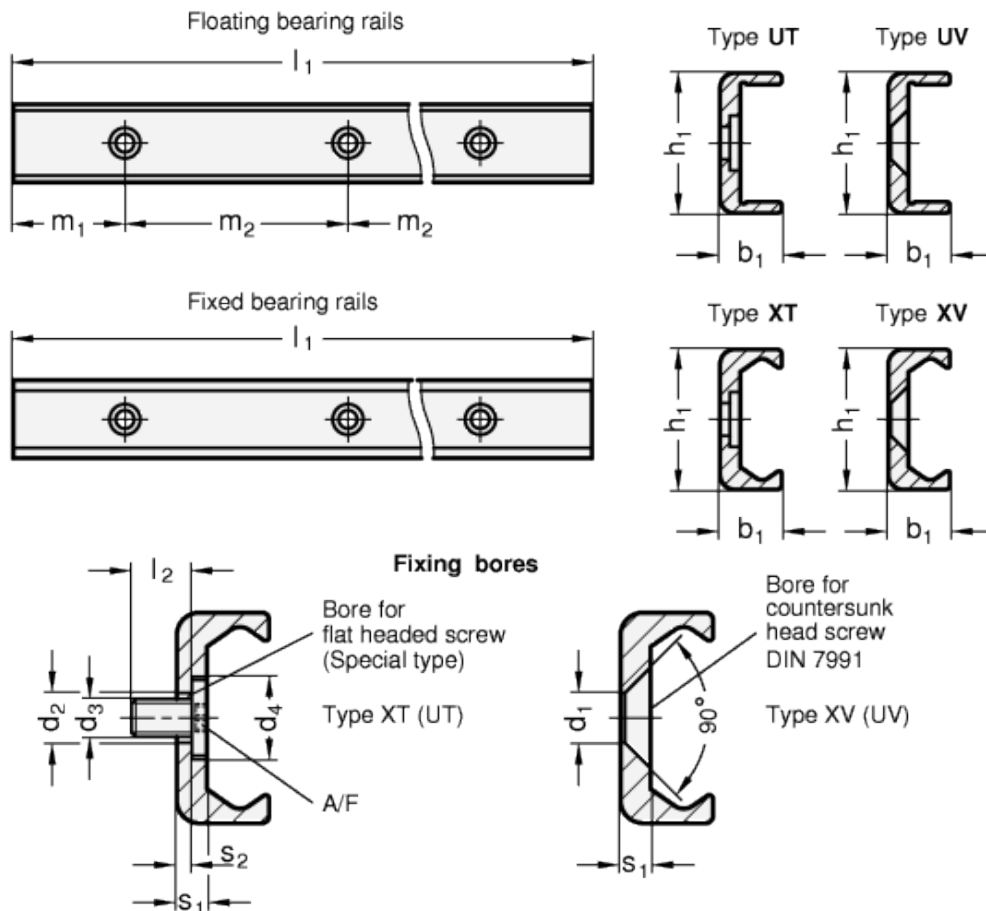

technical informations

Specification

Type

- Type UT: Floating bearing rail, mounting hole with sink
- Type UV: Floating bearing rail, mounting hole with conical sink

- Type XT: Fixed bearing rail, mounting hole with sink
- Type XV: Fixed bearing rail, mounting hole with conical sink

Heat treatable steel

- zinc plated, blue passivated
- Raceways hardened, ground

Flat head screws (only for type UT / XT)

Steel

zinc plated, blue passivated

Information

Rails GN 2422 are combined into roller guide systems together with the roller carriages GN 2424 or the rollers GN 2426. These space-saving units are suitable e.g. for carrying sliding doors or used in mechanical engineering or jigmaking for the linear traversal of plant sections.

These systems feature high stability and quiet running also at high traversal speeds. Thanks to the option of combining fixed and floating bearing rails, they make no great demands on the surrounding construction and so allow parallelism errors to be compensated. Flat headed screws with low head are included with the rail types UT / XT.

Accessory

- Roller carriages GN 2424
- Rollers GN 2426

On request

- other rail lengths (up to max. 3600 mm)
- other fixing hole distance m1/m2

Roller guide system

Roller guide systems allow the reliable and economical linear movement of hardware modules. Their outstanding attributes are low-maintenance operation, long service life and quiet running. These are attributes which make roller guide systems indispensable components for efficient and safe devices and plants with low energy need.

The product range includes all components necessary for making roller guide systems which are compact and easy to assemble and install. All roller guide systems consist of one outer rail with rollers or roller carriages moving inside this rail.

Rails are the foundations for roller guide systems. They can be made as fixed or floating bearing versions, with the fixed bearing variant guiding the rollers running inside the rail on two levels, while the floating bearing variant doing so only on one level. By combining both versions, any misalignments or parallelism errors in the connected construction can be compensated. Complex preliminary work caused by the precision machining of surrounding parts can so be kept to a minimum. Both rail versions can be attached in two different ways: cylindrical countersunk holes or 90° conical holes for the self-centering assembly are available.

Roller carriages are available in 3 different types of construction, differing by their radial or axial assembly option, their material and their degree of sealing. All roller carriages are fitted with 3 rollers, with the middle one always supplied with an eccentrically adjustable bearing pivot for determining the initial tension or the clearance/play inside the rail. Depending on rail version, a wiper is mounted on either end of the roller carriage.

Rollers are similar in structure to deep-groove ball bearings, with a non-detachable bearing pivot used as fixing element. For special applications, rollers and wipers can also be supplied separately from the roller carriages under separate standards. All design variants are available in the nominal rail dimensions $h_1 = 18, 28, 35$ and 43 mm. Beyond the standard range, they can also be supplied in lengths of up to 3600 mm in one piece, or as combined rails for individual and customised requirements.

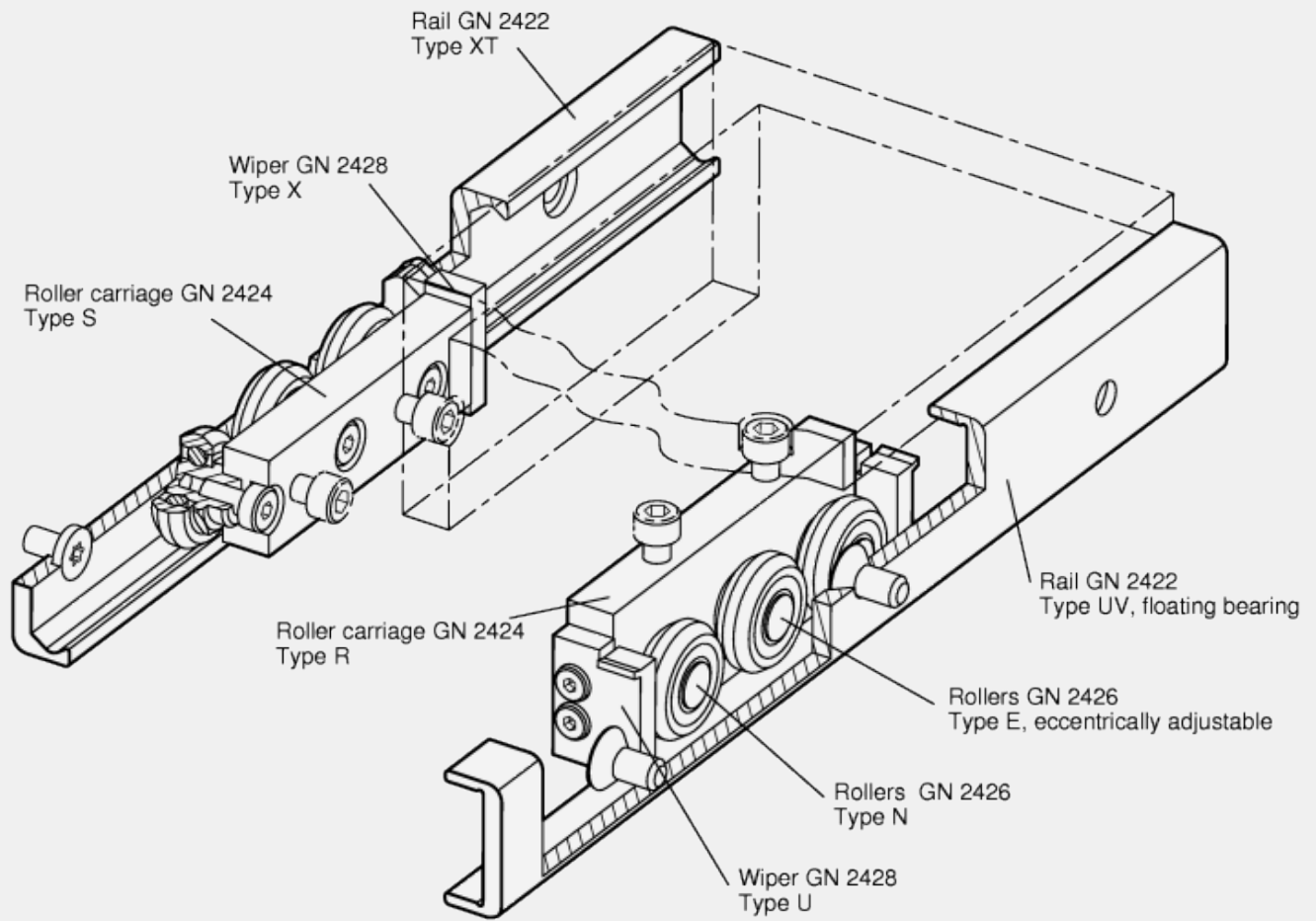

Rails

To safeguard maximum flexibility, roller guide systems are made from the elements listed below. Depending on requirement, the appropriate components can be supplied in the desired quantity. As the rails and the roller carriages must be assembled separately in many applications, these items will be supplied non-assembled and packed separately. On request, fully pre-assembled roller guide systems including rails GN 2422 and roller carriages GN 2424 are available.

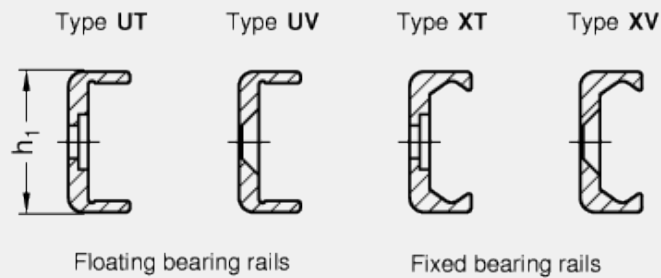

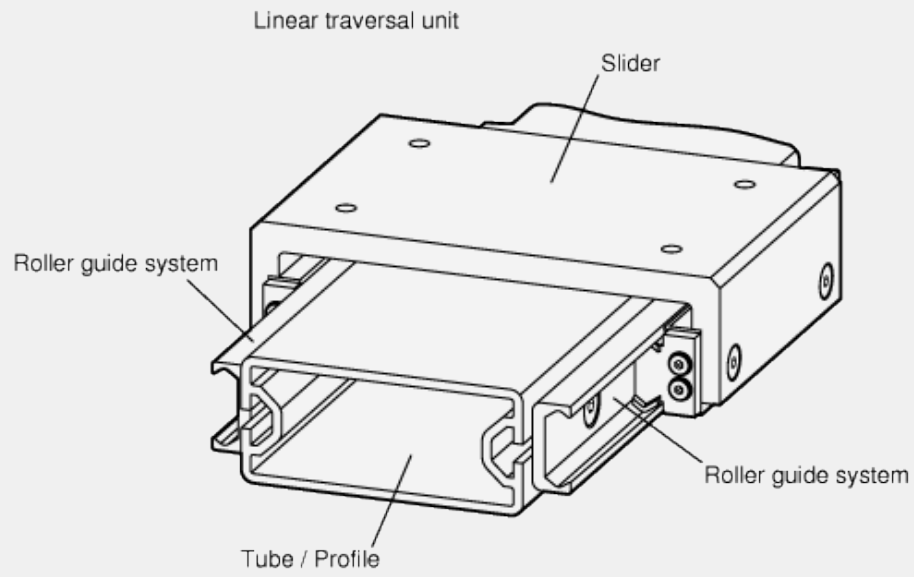
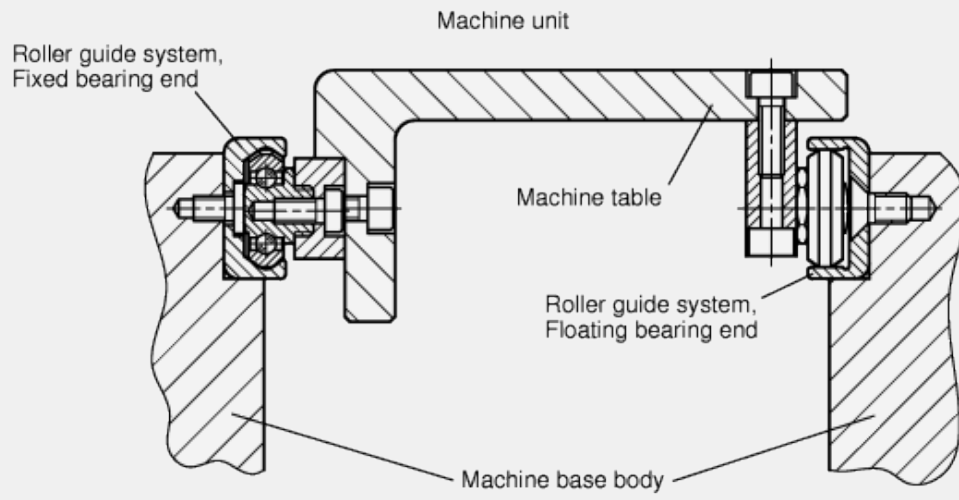

Roller guide systems

Tolerance for mounted roller guide systems

In the combination of rails GN 2422 and roller carriages GN 2424, the following dimensions / tolerances exist.

If several roller carriages are set for reversal into one rail, an offset x can occur between the roller carriages which must be added to the dimension h_2 .

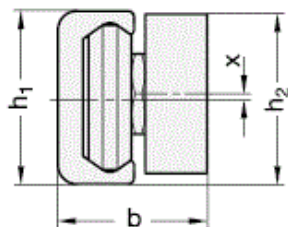

	h_1	b	h_2	x
18	+0,25/-0,10	+0,15/-0,16	+0,25/-0,25	±0,20
28	+0,25/-0,10	+0,25/-0,10	+0,15/-0,35	±0,20
35	+0,35/-0,10	+0,25/-0,10	+0,10/-0,30	±0,20
43	+0,36/-0,10	+0,25/-0,10	+0,20/-0,35	±0,20

Guidance accuracy

Roller guide systems feature the linear guidance accuracy shown in the diagram.

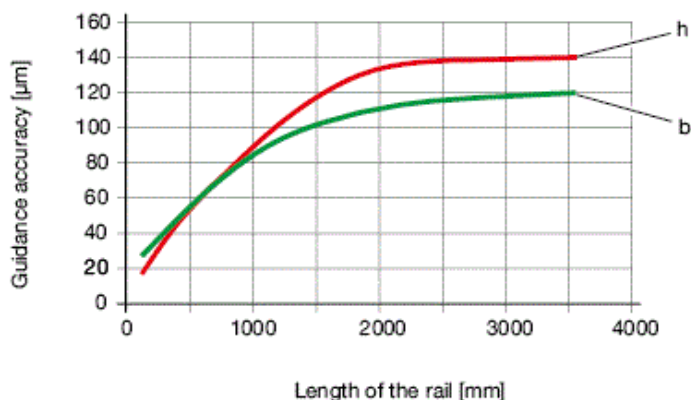
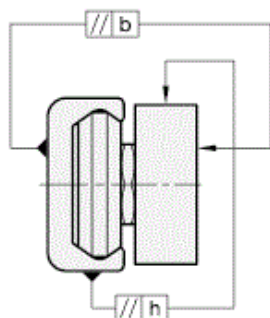

Permissible height offset

The fixed and floating bearing principle ensures that misalignments in the base construction are compensated. When using Type UV / UT and XV / XT rails, certain limits should not be exceeded, however. The following table shows the maximum permissible angle of the height offset of the fixed and floating bearing rails. Please note that the load rating must be reduced by 30% once the specified value is reached.

To calculate h_2 , the following equation should be used: $h_2 = a \times \tan w$, with the tabular values shown below used for w .

Example: $h_1 = 43$, $a = 650$ mm, w max. = $0,171^\circ$

$$h_2 = 650 \text{ mm} \times \tan 0,171^\circ = 1,94 \text{ mm}$$

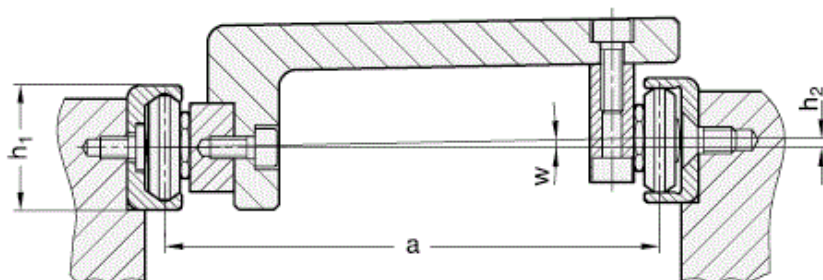

h_1	w max.
18	$0,057^\circ$
28	$0,143^\circ$
35	$0,151^\circ$
43	$0,171^\circ$

Permissible lateral offset

It is possible to compensate angular defects and the offset of mounting surface with the help of the fixed and floating bearing rails. The permissible offset of rollers and roller carriages in the Type UT / UV rails is given by the values for x and z. The reference is the nominal middle of the raceway b_m .

A parallelism or angular error can so be compensated across the whole length of the rail length which corresponds to an offset from the sum of the values for x and z.

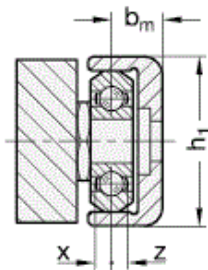

h_1	b_m	x	z
18	6,3	1,1	0,3
28	8,6	1,3	0,7
35	10,5	2,7	1,3
43	14,5	2,5	1,5

Support widths

To guarantee the proper running motion, outside dimensions must be observed during the assembly of roller guide systems. Suitable elements include supports at the rail and at the roller carriage which should not be smaller than the widths a or b. Also, forces acting from the outside can so be transferred reliably from the roller guide system without exposing the fixing screw to shear stress.

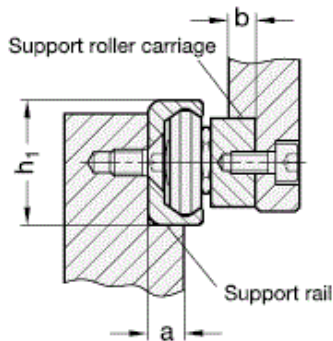

h_1	a	b
18	5	4
28	8	4
35	11	5
43	14	5

Tightening torque

When setting countersinks in the rails Type UT and XT, make sure that the mounting holes of the attachment surfaces are sufficiently sunk.

The specified tightening torque of the flat headed screws must be maintained.

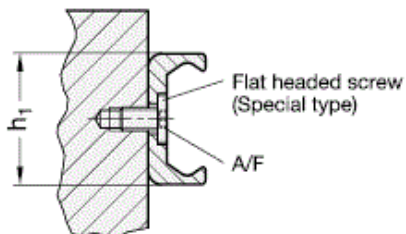

h_1	Screw	A/F Drive	Tightening torque
18	M 4 x 8	T20	3 Nm
28	M 5 x 10	T25	9 Nm
35	M 6 x 12	T30	14 Nm
43	M 8 x 16	T40	24 Nm

Traversal speed

Depending on application and installation length, the maximum traversal speed of roller guide systems is 7 m/s.

Lubrication

Once the roller carriage has been placed in the rail, it is recommended to slightly grease the raceway surfaces of the rail with a heavy duty lubricant for linear guide systems such as Klüberplex BE 31-222 using a brush.

Check the lubricant film at regular intervals for any dirt or pollution, e.g. with metal chips.

In the event of visible pollution or clear discoloration of the lubricant, use a clean rag to clean the rails and the rollers and apply new lubricant.

Applying new lubricant is normally necessary once every year or after 100 km of running distance.

Operational temperatures

The components of the roller guide systems are suitable for use in the temperature range from -30 °C to 130 °C.

Load rating

The installation space, the desired mode of attachment and the load to be carried are the decisive factors when selecting the best possible roller guide system. The values given below will help in selecting the most suitable roller carriage or the most suitable rollers.

The details on load capacity are non-binding guide values given without liability and do not constitute a warranty of a certain quality. The user must determine in each individual case whether a product is suitable for the intended application. Environmental factors and ageing may influence the stated values.

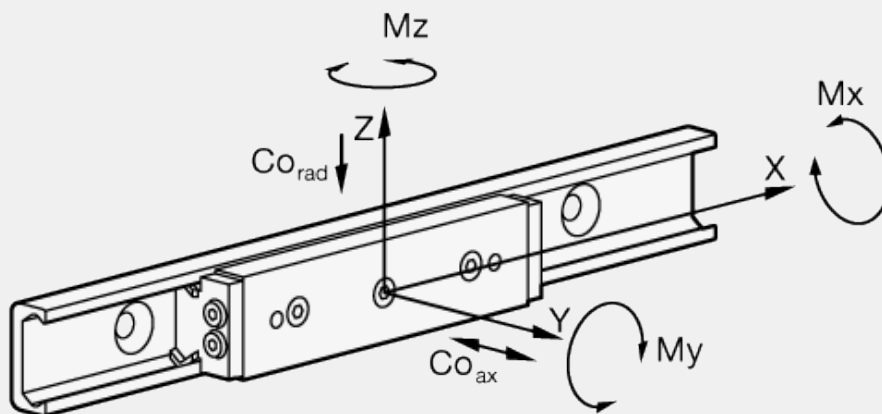

Roller guide systems consist of a GN 2422 rail and a GN 2424 roller carriage. All components are packed separately and supplied disassembled. When delivered, the play between roller carriage and rail is not preset.

During assembly, set the roller carriage as follows:

1. Make sure that the raceways and the rollers are clean.
2. Slightly loosen the fixing screw of the central, eccentrically adjustable roller and insert the roller carriage (without the wipers supplied) into the rail (see also Items 4 and 6).
3. Position the roller carriage at one end of the rail. For the floating bearing rails of Type UT and UV, a thin and stable support (e.g. a fork wrench or a feeler gauge) must be placed underneath the ends of the roller carriage body and the rail to ensure the parallel alignment of the roller carriage in the level raceways.

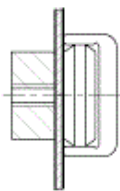

Use support for floating bearing rails!

4. Insert the GN 2424.1 fork wrench (enclosed) between the eccentric roller and the roller carriage body. (The centering bores to the left and right mark the position of the running side of the concentric rollers / load-bearing rollers.)

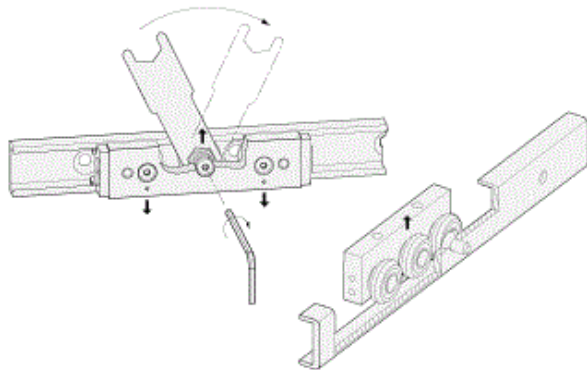

5. Turning the fork wrench clockwise will press the roller to be adjusted against the top raceway which will set the roller carriage free of play. Excessive pre-tensioning must be avoided because this will increase friction and reduce the useful service life.

6. While using the fork wrench to hold the bearing pivot in the correct position, the fixing screw may be moderately tightened. The correct tightening torque will be checked later.

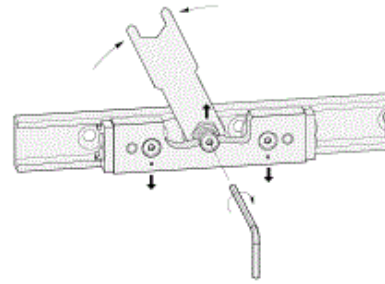

7. Move the roller carriage in the rail and make sure that the play / the moderate pre-tensioning is constant along the full length of the rail. The running motion should be free-moving, with the roller carriage having no play or jamming at no point inside the rail.

8. Now tighten the fixing screw with the prescribed tightening torque shown in the table, with the fork wrench holding the angular position of the rollers in place.

h_1	Tightening torque
18	3 Nm
28	7 Nm
35	7 Nm
43	12 Nm

9. Now mount the wipers, also the longitudinal seal for roller carriage Type N. To do so, remove the roller carriage from the rail.

10. Before reinserting the roller carriage, make sure that the raceways / rollers are properly lubricated using a heavy duty lubricant for linear guidance.

Description	h_1	l_1	m_1	b_1	d_1	d_2	d_3	d_4	l_2	m_2	s_1	s_2	A/F	g
GN 2422-18-240-40-UT	18	240	40	8.3	-	5	M 4	9.5	8	80	2.8	2.2	T 20	132
GN 2422-18-400-40-UT	18	240	40	8.3	-	5	M 4	9.5	8	80	2.8	2.2	T 20	220
GN 2422-18-560-40-UT	18	560	40	8.3	-	5	M 4	9.5	8	80	2.8	2.2	T 20	308
GN 2422-18-800-40-UT	18	800	40	8.3	-	5	M 4	9.5	8	80	2.8	2.2	T 20	440
GN 2422-18-1040-40-UT	18	1040	40	8.3	-	5	M 4	9.5	8	80	2.8	2.2	T 20	572
GN 2422-18-1200-40-UT	18	1200	40	8.3	-	5	M 4	9.5	8	80	2.8	2.2	T 20	660
GN 2422-28-400-40-UT	28	400	40	12.3	-	6.4	M 5	11	10	80	4	2.2	T 25	484
GN 2422-28-560-40-UT	28	560	40	12.3	-	6.4	M 5	11	10	80	4	2.2	T 25	678
GN 2422-28-800-40-UT	28	800	40	12.3	-	6.4	M 5	11	10	80	4	2.2	T 25	968
GN 2422-28-1040-40-UT	28	1040	40	12.3	-	6.4	M 5	11	10	80	4	2.2	T 25	1258
GN 2422-28-1200-40-UT	28	1200	40	12.3	-	6.4	M 5	11	10	80	4	2.2	T 25	1452
GN 2422-28-1440-40-UT	28	1440	40	12.3	-	6.4	M 5	11	10	80	4	2.2	T 25	1742
GN 2422-35-400-40-UT	35	400	40	16.5	-	8	M 6	15	12	80	3.5	2.7	T 30	636
GN 2422-35-560-40-UT	35	560	40	16.5	-	8	M 6	15	12	80	3.5	2.7	T 30	890
GN 2422-35-800-40-UT	35	800	40	16.5	-	8	M 6	15	12	80	3.5	2.7	T 30	1272
GN 2422-35-1040-40-UT	35	1040	40	16.5	-	8	M 6	15	12	80	3.5	2.7	T 30	1654
GN 2422-35-1200-40-UT	35	1200	40	16.5	-	8	M 6	15	12	80	3.5	2.7	T 30	1908
GN 2422-35-1440-40-UT	35	1440	40	16.5	-	8	M 6	15	12	80	3.5	2.7	T 30	2290
GN 2422-43-400-40-UT	43	400	40	21	-	10.5	M 8	18	16	80	4.5	3	T 40	1004
GN 2422-43-560-40-UT	43	560	40	21	-	10.5	M 8	18	16	80	4.5	3	T 40	1406
GN 2422-43-800-40-UT	43	800	40	21	-	10.5	M 8	18	16	80	4.5	3	T 40	2008
GN 2422-43-1040-40-UT	43	1040	40	21	-	10.5	M 8	18	16	80	4.5	3	T 40	2610
GN 2422-43-1200-40-UT	43	1200	40	21	-	10.5	M 8	18	16	80	4.5	3	T 40	3012
GN 2422-43-1520-40-UT	43	1520	40	21	-	10.5	M 8	18	16	80	4.5	3	T 40	3815
GN 2422-43-2000-40-UT	43	2000	40	21	-	10.5	M 8	18	16	80	4.5	3	T 40	4500
GN 2422-18-240-40-UV	18	240	40	8.3	4.5	-	-	-	-	80	2.8	-	-	132
GN 2422-18-400-40-UV	18	400	40	8.3	4.5	-	-	-	-	80	2.8	-	-	220
GN 2422-18-560-40-UV	18	560	40	8.3	4.5	-	-	-	-	80	2.8	-	-	308
GN 2422-18-800-40-UV	18	800	40	8.3	4.5	-	-	-	-	80	2.8	-	-	440
GN 2422-18-1040-40-UV	18	1040	40	8.3	4.5	-	-	-	-	80	2.8	-	-	572
GN 2422-18-1200-40-UV	18	1200	40	8.3	4.5	-	-	-	-	80	2.8	-	-	660
GN 2422-28-400-40-UV	28	400	40	12.3	5.5	-	-	-	-	80	4	-	-	484
GN 2422-28-560-40-UV	28	560	40	12.3	5.5	-	-	-	-	80	4	-	-	678
GN 2422-28-800-40-UV	28	800	40	12.3	5.5	-	-	-	-	80	4	-	-	968
GN 2422-28-1040-40-UV	28	1040	40	12.3	5.5	-	-	-	-	80	4	-	-	1258
GN 2422-28-1200-40-UV	28	1200	40	12.3	5.5	-	-	-	-	80	4	-	-	1452
GN 2422-28-1440-40-UV	28	1440	40	12.3	5.5	-	-	-	-	80	4	-	-	1742
GN 2422-35-400-40-UV	35	400	40	16.5	6.5	-	-	-	-	80	3.5	-	-	636
GN 2422-35-560-40-UV	35	560	40	16.5	6.5	-	-	-	-	80	3.5	-	-	890
GN 2422-35-800-40-UV	35	800	40	16.5	6.5	-	-	-	-	80	3.5	-	-	1272
GN 2422-35-1040-40-UV	35	1040	40	16.5	6.5	-	-	-	-	80	3.5	-	-	1654
GN 2422-35-1200-40-UV	35	1200	40	16.5	6.5	-	-	-	-	80	3.5	-	-	1908
GN 2422-35-1440-40-UV	35	1440	40	16.5	6.5	-	-	-	-	80	3.5	-	-	2290

GN 2422-43-400-40-UV	43	400	40	21	8.5	-	-	-	-	80	4.5	-	-	1004
GN 2422-43-560-40-UV	43	560	40	21	8.5	-	-	-	-	80	4.5	-	-	1406
GN 2422-43-800-40-UV	43	800	40	21	8.5	-	-	-	-	80	4.5	-	-	2008
GN 2422-43-1040-40-UV	43	1040	40	21	8.5	-	-	-	-	80	4.5	-	-	2610
GN 2422-43-1200-40-UV	43	1200	40	21	8.5	-	-	-	-	80	4.5	-	-	3012
GN 2422-43-1520-40-UV	43	1520	40	21	8.5	-	-	-	-	80	4.5	-	-	3815
GN 2422-43-2000-40-UV	43	2000	40	21	8.5	-	-	-	-	80	4.5	-	-	4500
GN 2422-18-240-40-XT	18	240	40	8.3	-	5	M 4	9.5	8	80	2.8	2.2	T 20	132
GN 2422-18-400-40-XT	18	400	40	8.3	-	5	M 4	9.5	8	80	2.8	2.2	T 20	220
GN 2422-18-560-40-XT	18	560	40	8.3	-	5	M 4	9.5	8	80	2.8	2.2	T 20	308
GN 2422-18-800-40-XT	18	800	40	8.3	-	5	M 4	9.5	8	80	2.8	2.2	T 20	440
GN 2422-18-1040-40-XT	18	1040	40	8.3	-	5	M 4	9.5	8	80	2.8	2.2	T 20	572
GN 2422-18-1200-40-XT	18	1200	40	8.3	-	5	M 4	9.5	8	80	2.8	2.2	T 20	660
GN 2422-28-400-40-XT	28	400	40	12.3	-	6.4	M 5	11	10	80	4	2.2	T 25	484
GN 2422-28-560-40-XT	28	560	40	12.3	-	6.4	M 5	11	10	80	4	2.2	T 25	678
GN 2422-28-800-40-XT	28	800	40	12.3	-	6.4	M 5	11	10	80	4	2.2	T 25	968
GN 2422-28-1040-40-XT	28	1040	40	12.3	-	6.4	M 5	11	10	80	4	2.2	T 25	1258
GN 2422-28-1200-40-XT	28	1200	40	12.3	-	6.4	M 5	11	10	80	4	2.2	T 25	1452
GN 2422-28-1440-40-XT	28	1440	40	12.3	-	6.4	M 5	11	10	80	4	2.2	T 25	1742
GN 2422-35-400-40-XT	35	400	40	16.5	-	8	M 6	15	12	80	3.5	2.7	T 30	636
GN 2422-35-560-40-XT	35	560	40	16.5	-	8	M 6	15	12	80	3.5	2.7	T 30	890
GN 2422-35-800-40-XT	35	800	40	16.5	-	8	M 6	15	12	80	3.5	2.7	T 30	1272
GN 2422-35-1040-40-XT	35	1040	40	16.5	-	8	M 6	15	12	80	3.5	2.7	T 30	1654
GN 2422-35-1200-40-XT	35	1200	40	16.5	-	8	M 6	15	12	80	3.5	2.7	T 30	1908
GN 2422-35-1440-40-XT	35	1440	40	16.5	-	8	M 6	15	12	80	3.5	2.7	T 30	2290
GN 2422-43-400-40-XT	43	400	40	21	-	10.5	M 8	18	16	80	4.5	3	T 40	1004
GN 2422-43-560-40-XT	43	560	40	21	-	10.5	M 8	18	16	80	4.5	3	T 40	1406
GN 2422-43-800-40-XT	43	800	40	21	-	10.5	M 8	18	16	80	4.5	3	T 40	2008
GN 2422-43-1040-40-XT	43	1040	40	21	-	10.5	M 8	18	16	80	4.5	3	T 40	2610
GN 2422-43-1200-40-XT	43	1200	40	21	-	10.5	M 8	18	16	80	4.5	3	T 40	3012
GN 2422-43-1520-40-XT	43	1520	40	21	-	10.5	M 8	18	16	80	4.5	3	T 40	3815
GN 2422-43-2000-40-XT	43	2000	40	21	-	10.5	M 8	18	16	80	4.5	3	T 40	4500
GN 2422-18-240-40-XV	18	240	40	8.3	4.5	-	-	-	-	80	2.8	-	-	132
GN 2422-18-400-40-XV	18	400	40	8.3	4.5	-	-	-	-	80	2.8	-	-	220
GN 2422-18-560-40-XV	18	560	40	8.3	4.5	-	-	-	-	80	2.8	-	-	308
GN 2422-18-800-40-XV	18	800	40	8.3	4.5	-	-	-	-	80	2.8	-	-	440
GN 2422-18-1040-40-XV	18	1040	40	8.3	4.5	-	-	-	-	80	2.8	-	-	572
GN 2422-18-1200-40-XV	18	1200	40	8.3	4.5	-	-	-	-	80	2.8	-	-	660
GN 2422-28-400-40-XV	28	400	40	12.3	5.5	-	-	-	-	80	4	-	-	484
GN 2422-28-560-40-XV	28	560	40	12.3	5.5	-	-	-	-	80	4	-	-	678
GN 2422-28-800-40-XV	28	800	40	12.3	5.5	-	-	-	-	80	4	-	-	968
GN 2422-28-1040-40-XV	28	1040	40	12.3	5.5	-	-	-	-	80	4	-	-	1258
GN 2422-28-1200-40-XV	28	1200	40	12.3	5.5	-	-	-	-	80	4	-	-	1452
GN 2422-28-1440-40-XV	28	1440	40	12.3	5.5	-	-	-	-	80	4	-	-	1752
GN 2422-35-400-40-XV	35	400	40	16.5	6.5	-	-	-	-	80	3.5	-	-	636

GN 2422-35-560-40-XV	35	560	40	16.5	6.5	-	-	-	-	80	3.5	-	-	890
GN 2422-35-800-40-XV	35	800	40	16.5	6.5	-	-	-	-	80	3.5	-	-	1272
GN 2422-35-1040-40-XV	35	1040	40	16.5	6.5	-	-	-	-	80	3.5	-	-	1654
GN 2422-35-1200-40-XV	35	1200	40	16.5	6.5	-	-	-	-	80	3.5	-	-	1908
GN 2422-35-1440-40-XV	35	1440	40	16.5	6.5	-	-	-	-	80	3.5	-	-	2290
GN 2422-43-400-40-XV	43	400	40	21	8.5	-	-	-	-	80	4.5	-	-	1004
GN 2422-43-560-40-XV	43	560	40	21	8.5	-	-	-	-	80	4.5	-	-	1406
GN 2422-43-800-40-XV	43	800	40	21	8.5	-	-	-	-	80	4.5	-	-	2008
GN 2422-43-1040-40-XV	43	1040	40	21	8.5	-	-	-	-	80	4.5	-	-	2610
GN 2422-43-1200-40-XV	43	1200	40	21	8.5	-	-	-	-	80	4.5	-	-	3012
GN 2422-43-1520-40-XV	43	1520	40	21	8.5	-	-	-	-	80	4.5	-	-	3815
GN 2422-43-2000-40-XV	43	2000	40	21	8.5	-	-	-	-	80	4.5	-	-	4500



STANDARD MACHINE ELEMENTS WORLDWIDE